

SERIES 65-72

Floating Ball Valves

Two-Piece, Full and Reduced Port

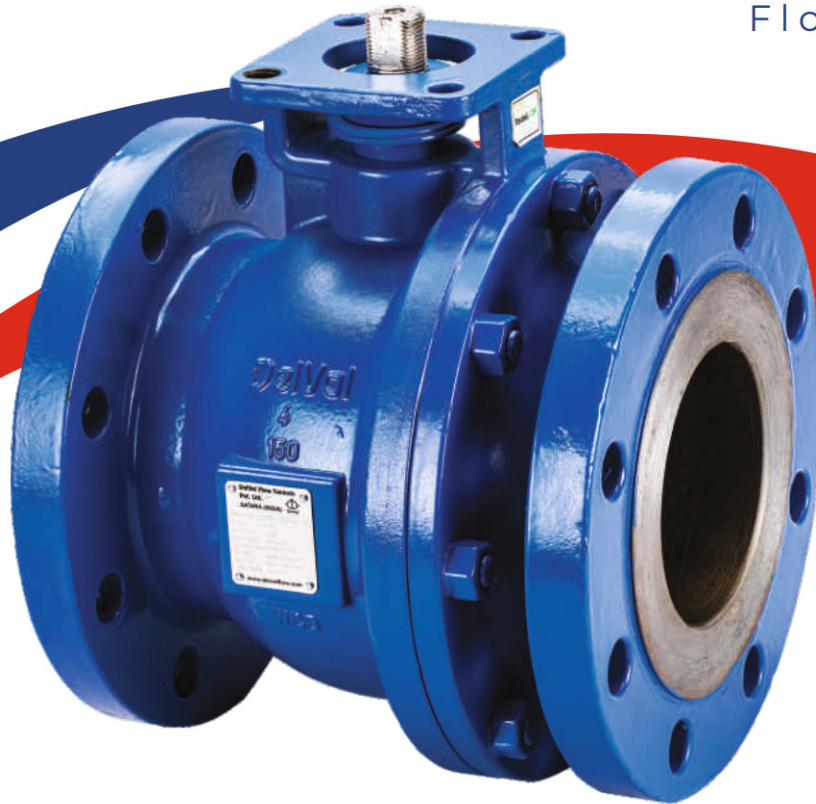

delvalflow.com

1-833-DELVAL1



STANDARD FEATURES

Quality & Performance

DeVal Flow Controls provides a wide range of quality products with the reliability you can count on. All Series 65-72 floating side entry ball valves are manufactured in ISO 9001 certified facilities with a robust quality management system and according to ASME B16.34, API 6D and BS EN ISO 17292 standards.

Design Construction and Features

1. Top Flange Drilling

Integral Top Flange is designed as per ISO 5211 for direct mounting of actuators and gear operators. Top flange design provides easy access for adjustment of gland bolts when the valve is mounted with actuators.

2. Adjustable Packing Gland

Packing gland bolts are easily accessible to adjust packing with the actuator in place.

3. Valve Body

Flanged, two-piece design in cast construction. Flanges are raised face and serrated and dimensions conform to ASME B 16.5. Carbon steel valve bodies are finished with two coats of hard, zinc-rich epoxy for excellent corrosion resistance.

4. Ball

Floating design, precision machined ball with superior finish and sphericity ensures extended seat life and low operating torques. The combination of the balanced seat design and ball ensures consistent and dependable leak tightness.

5. Stem

Stem in stainless steel, heavy-duty construction with double "D" or round and keyed configurations for positive engagement with all types of valve operators.

6. Seat

Seat is contoured to ensure that all stresses due to the line pressure are counter balanced and that the extrusion of the seat into the body cavity due to sealing forces is eliminated.

7. Stem Sealing

A multiple stem sealing arrangement prevents leakage to the atmosphere. Stem packing in graphite is live loaded with the gland assembly to ensure positive and trouble free sealing. Adjustment of packing gland is accessible without disassembly of valve or operator parts. O-ring provides sealing against fugitive emissions.

8. Antistatic Device

Antistatic devices at the ball-stem interface and body-stem interface. This device ensures electrical conductivity between valve ball, stem and the body, thus eliminating the possibility of static electrical charges creating sparks within the valve.

9. Stem Seal

Heavy-duty engineered seal is provided to absorb side and thrust loads. It also reduces stem torque, protects stem packing from deformation and gives extended stem sealing life.

10. Body Seal

Body joint sealing is by a graphite/ reinforced graphite gasket (6" and above) to withstand high temperatures and is contained in a precision-machined groove for extended sealing life.

11. Body Cavity Drain Plug

Body cavity drain plug facility is available on request.

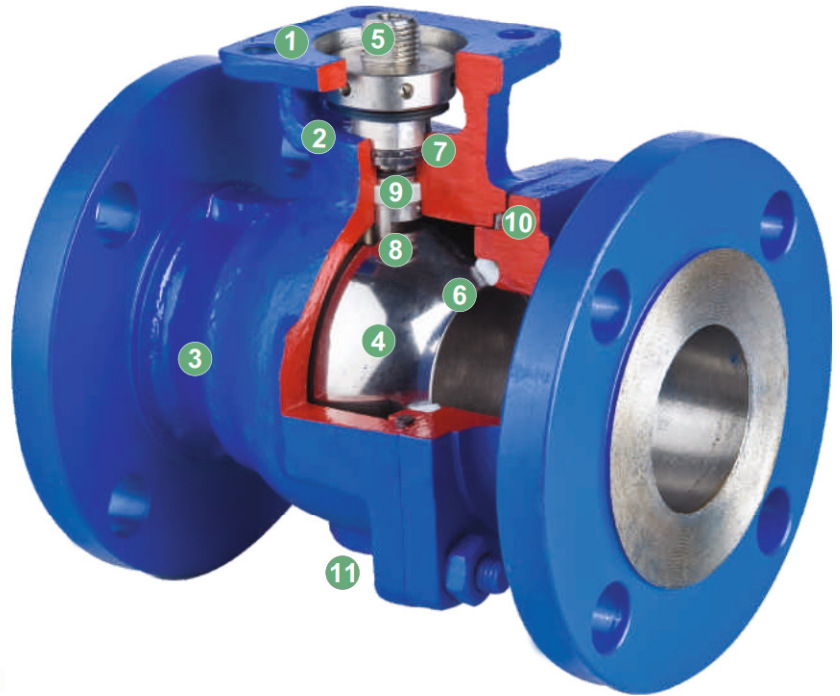

Pressure Temperature Ratings

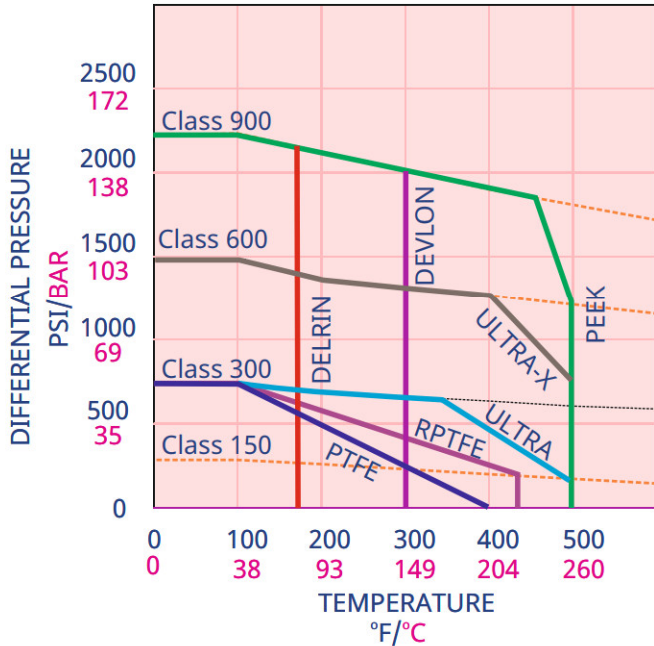

Temperature Limits

Material	*Temperature Limits				
	Lower Limit		Upper Limit		
	°F	°C	°F	°C	
BODY	WCB	-20	-29	800	425
	LCB	-50	-46	650	345
	CF8/CF3	-320	-196	1000	538
	CF8M/CF3M	-320	-196	1000	538
SEAT	PTFE	-40	-40	392	200
	RPTFE	-58	-50	428	220
	ULTRA	-58	-50	500	260
	ULTRA-X	-58	-50	500	260
	DEVLON®	-58	-50	302	150
	PEEK	-58	-50	500	260
	DELRIN	14	-10	176	80
SEAL	HNBR-AED	-50	-46	302	150
	VITON® AED	5	-15	392	200
	VITON® B	-4	-20	392	200

*Pressure-temperating rating shall be lesser of the shell rating or the seat rating or seal rating.

Note: These ratings are a guide for general service.

Please consult DelVal for specific recommendations.

ULTRA Seat

An engineered fluorocarbon polymer that is rated for 200°C/500°F. Excellent for handling aggressive fluids at high pressures, Ultra is recommended for extended service in hostile environments involving chemical, thermal, and mechanical stress. Ultra has excellent thermal stability and is ideal for steam, hot gases and a variety of process chemicals where service can also be subject to pressure cycling.

Standards and Specifications

DelVal Series 65-72 Floating Side Entry Ball Valves are designed and manufactured to meet the requirements of the following industry standards:

Design: API 6D, BS EN ISO 17292, ASME B16.34

Face to Face: API 6D, ASME B16.10

Testing: API 6D, API 598, ISO 5208

Pressure Temperature: ASME B16.34

Flange Accommodation: ASME B16.5, BS EN 1092

Butt Weld Ends: ASME B16.25

NACE: ANSI/ASME MR 0175/ISO 15156-1

Fire Safe Certified: API 6FA/API 607

Fugitive Emission: ISO 15848 -1&2

Compliance: PED 2014/68/EU

Body Style: Flanged end/Butt weld end

Rating: Class 150 to Class 1500

***Temp Range:** -46°C to 200°C
-50°F to 392°F

****Size Range:** 2" to 12"

*Pressure-temperature rating shall be the lesser of the shell rating or the seat rating or the seal rating.

**Consult DelVal for sizes not available in the bulletin.

DIMENSIONS AND WEIGHTS (FULL PORT)

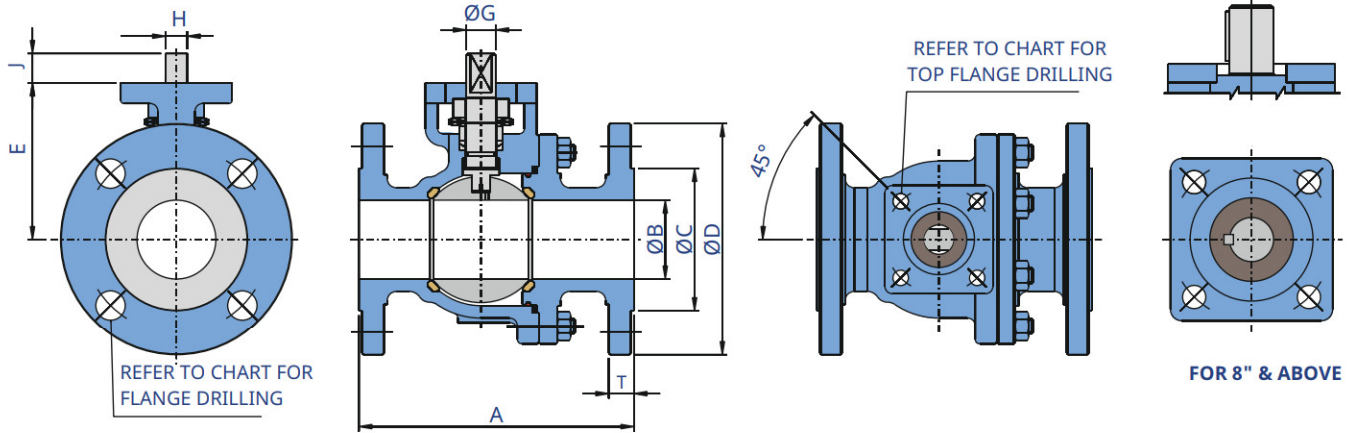

Dimensions (mm)

ASME Class 150 (Series 65)

Valve Size		A		T	ØB	ØC	E	ØD	Flange Drilling			ØG	H	J	Key Size	Top Flange Drilling			App. Weight (kg)	
Inch	DN	LP	SP						PCD	Hole Ø	Nos.					ISO 5211 Pattern	PCD1	Hole Ø		Nos.
½"	15	108		9.5	15	35.0	45.0	89	60.5	16.0	4	10	6	2.50	-	F05	50	7	4	1.4
¾"	20	117		10.9	20	43.0	52.0	100	69.9	16.0	4	10	6	6.00	-	F05	50	7	4	2.0
1"	25	127		11.6	25	51.0	65.0	110	79.4	16.0	4	16	11	6.50	-	F05	50	7	4	2.8
1¼"	32	140		12.7	32	63.5	70.0	117	88.9	16.0	4	16	11	6.15	-	F05	50	7	4	3.1
1½"	40	165		15.0	38	73.0	84.0	125	98.5	16.0	4	16	11	9.00	-	F05	50	7	4	5.2
2"	50	178		16.3	51	92.0	90.0	150	120.7	19.0	4	16	11	7.50	-	F07	70	10	4	8.1
2½"	65	190		18.0	62	105.0	107.0	180	139.7	19.0	4	18	13	18.00	-	F07	70	10	4	12.5
3"	80	203		19.5	76	127.0	120.5	190	152.4	19.0	4	19	13	16.00	-	F10	102	12	4	15.5
4"	100	229		24.3	102	157.2	153.0	230	190.5	19.0	8	22	16	16.00	-	F10	102	12	4	29.5
5"	125	267		24.3	125	185.7	200.0	255	215.9	22.2	8	30	22	25.00	-	F12	125	14	4	56.0
6"	150	394	267	26.0	150	216.0	215.0	280	241.3	22.2	8	30	22	25.00	-	F12	125	14	4	60.5
8"	200	457	-	30.0	202	270.0	296.5	345	298.5	22.2	8	40	-	45.00	12 x 8	F16	165	22	4	139.0
10"	250	533	-	31.0	252	324.0	352.0	405	362.0	25.4	12	42	-	67.00	12 x 8	F16	165	22	4	212.0
12"	300	610	-	32.5	305	381.0	465.0	485	431.8	25.4	12	60	-	84.00	18 x 11	F25	254	18	8	360.0

ASME Class 300 (Series 66)

½"	15	140		14.7	15	34.9	45.0	95	66.7	16.0	4	10	6	2.50	-	F05	50	7	4	1.6
¾"	20	152		16.3	20	43.0	52.0	115	82.6	19.0	4	10	6	6.00	-	F05	50	7	4	2.2
1"	25	165		17.9	25	50.8	65.0	125	88.9	19.0	4	16	11	6.50	-	F05	50	7	4	4.2
1¼"	32	178		19.0	32	63.5	70.0	133	98.6	19.0	4	16	11	6.15	-	F05	50	7	4	5.5
1½"	40	190		21.1	38	73.0	84.0	155	114.3	22.2	4	16	11	9.00	-	F05	50	7	4	8.0
2"	50	216		22.7	51	92.0	90.0	165	127.0	19.0	8	16	11	7.50	-	F07	70	10	4	11.2
2½"	65	241		25.9	62	105.0	107.0	190	149.2	22.2	8	18	13	18.00	-	F07	70	10	4	19.5
3"	80	282		29.0	76	127.0	120.5	210	168.3	22.2	8	19	13	16.00	-	F10	102	12	4	29.0
4"	100	305		32.2	102	157.2	153.0	255	200.0	22.2	8	22	16	16.00	-	F10	102	12	4	45.5
5"	125	403		35.4	125	185.7	200.0	280	235.0	22.2	8	30	22	25.00	-	F12	125	14	4	68.0
6"	150	403		37.0	150	216.0	215.0	320	269.9	22.2	12	30	22	25.00	-	F12	125	14	4	95.0
8"	200	502	419	42.0	202	270.0	296.5	380	330.2	25.4	12	40	-	45.00	12 x 8	F16	165	22	4	160.0

ASME Class 600 (Series 67)

½"	15	165		20.8	15	35.0	65	95	66.7	16.0	4	16	11	3.0	-	F07	70	10	4	7.5
¾"	20	190		22.9	20	43.0	65	115	82.6	19.0	4	16	11	3.0	-	F07	70	10	4	8.5
1"	25	216		24.0	25	50.0	65	125	88.9	19.0	4	16	11	3.0	-	F07	70	10	4	9.5
1½"	40	241		29.3	38	73.0	85	155	114.3	22.2	4	22	16	12.5	-	F07	70	10	4	11.0
2"	50	292		31.8	51	92.0	110	165	127.0	19.0	8	22	16	16.0	-	F10	102	12	4	19.5
2½"	65	330		35.0	62	105.0	132	190	149.2	22.2	8	30	22	22.0	-	F10	102	12	4	31.0
3"	80	356		38.2	76	127.0	150	210	168.3	22.2	8	30	22	22.0	-	F10	102	12	4	39.0
4"	100	432		44.5	102	157.2	175	275	215.9	25.4	8	35	24	35.0	-	F12	125	14	4	65.0

ASME Class 900 (Series 68)

1"	25	254		35.0	25	50.8	65	150	101.6	25.4	4	16	11	3.0	-	F07	70	10	4	18.0
1½"	40	305		38.2	38	73.0	95	180	123.8	28.5	4	30	22	15.5	-	F10	102	12	4	28.0
2"	50	368		44.5	51	92.0	110	215	165.1	25.4	8	30	22	20.0	-	F12	125	14	4	35.0

DIMENSIONS AND WEIGHTS (REDUCED PORT)

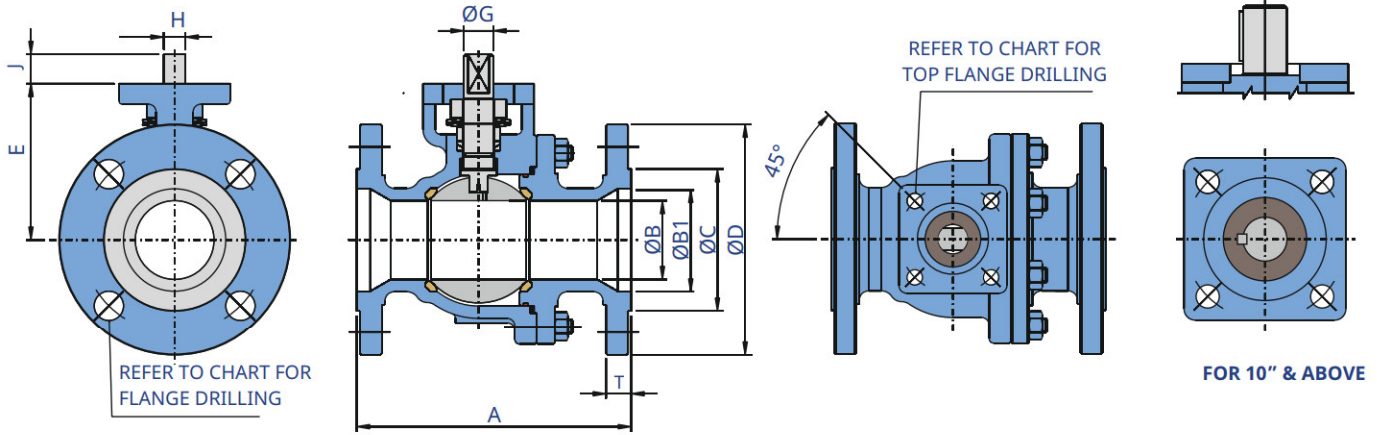

Dimensions (mm)

ASME Class 150 (Series 69)

Valve Size		A		T	ØB1	ØB	ØC	E	ØD	Flange Drilling			ØG	H	J	Key Size	Top Flange Drilling			App. Weight (kg)	
Inch	DN	LP	SP							PCD	Hole Ø	Nos.					ISO 5211 Pattern	PCD1	Hole Ø		Nos.
¾"	20	-	117	10.9	20	15	43.0	45.0	100	69.9	16.0	4	10	6	2.5	-	F05	50	7	4	1.1
1"	25	-	127	12.0	25	20	51.0	52.0	108	79.4	16.0	4	10	6	6.0	-	F05	50	7	4	1.8
1½"	40	-	165	14.7	38	25	73.0	65.0	125	98.5	16.0	4	16	11	6.5	-	F05	50	7	4	4.4
2"	50	-	178	16.3	51	38	92.0	84.0	150	120.7	19.0	4	16	11	9.0	-	F05	50	7	4	6.5
2½"	65	-	190	18.0	62	51	105.0	90.0	180	139.7	19.0	4	16	11	7.5	-	F07	70	10	4	9.0
3"	80	-	203	19.5	76	62	127.0	107.0	190	152.4	19.0	4	18	13	18.0	-	F07	70	10	4	14.5
4"	100	-	229	24.3	102	76	157.2	120.5	230	190.5	19.0	8	19	13	16.0	-	F10	102	12	4	24.5
6"	150	-	267	25.9	150	102	216.0	153.0	280	241.3	22.2	8	22	16	16.0	-	F10	102	12	4	32.0
8"	200	457	-	30.0	202	150	270.0	215.0	345	298.5	22.2	8	30	22	25.0	-	F12	125	14	4	95.0
10"	250	533	-	31.0	252	202	324.0	296.5	405	362.0	25.4	12	40	-	45.0	12 x 8	F16	165	22	4	201.0
12"	300	610	-	32.5	305	252	381.0	352.0	485	431.8	25.4	12	42	-	62.0	12 x 8	F16	165	22	4	310.0

ASME Class 300 (Series 70)

¾"	20	-	152	16.0	20.0	15	43.0	45.0	115.0	82.6	19.0	4	10	6	2.5	-	F05	50	7	4	2.0
1"	25	-	165	17.9	25.0	20	50.8	52.0	125.0	88.9	19.0	4	10	6	6.0	-	F05	50	7	4	3.0
1½"	40	-	190	21.1	38.0	25	73.0	65.0	155.0	114.3	22.2	4	16	11	6.5	-	F05	50	7	4	5.3
2"	50	-	216	22.7	51.0	38	92.0	84.0	165.0	127.0	19.0	8	16	11	9.0	-	F05	50	7	4	9.0
2½"	65	-	241	25.4	62.0	51	105.0	90.0	190.0	149.2	22.2	8	16	11	7.5	-	F07	70	10	4	16.0
3"	80	-	282	29.0	76.0	62	127.0	107.0	210.0	168.3	22.2	8	18	13	18.0	-	F07	70	10	4	21.5
4"	100	-	305	32.2	102.0	76	157.2	120.5	255.0	200.0	22.2	8	19	13	16.0	-	F10	102	12	4	34.8
6"	150	-	403	37.0	150.0	102	216.0	153.0	320.0	269.9	22.2	12	22	16	16.0	-	F10	102	12	4	79.0
8"	200	-	419	42.0	202.0	150	270.0	215.0	380.0	330.2	25.4	12	30	22	25.0	-	F12	125	14	4	145.0
10"	250	568.5	-	48.0	252.0	202	324.0	296.4	444.5	387.4	28.5	16	40	-	45.0	12 x 8	F16	165	22	4	269.5

ASME Class 600 (Series 71)

¾"	20	-	190	22.9	20	15	43.0	65	115	82.6	19.0	4	16	11	3.0	-	F07	70	10	4	8
1"	25	-	216	24.5	25	20	50.8	65	125	88.9	19.0	4	16	11	3.0	-	F07	70	10	4	9
1½"	40	-	241	29.3	38	25	73.0	65	155	114.3	22.2	4	16	11	3.0	-	F07	70	10	4	12
2"	50	-	292	31.8	51	38	92.0	85	165	127.0	19.0	8	22	16	12.5	-	F07	70	10	4	15
3"	80	-	356	38.8	76	62	127.0	132	210	168.3	22.2	8	30	22	22.0	-	F10	102	12	4	40
4"	100	-	432	44.9	102	76	157.2	150	275	215.9	25.4	8	30	22	22.0	-	F10	102	12	4	66
6"	150	-	559	54.7	150	102	216.0	175	355	292.0	28.5	12	35	24	35.0	-	F12	125	14	4	108

ASME Class 900 (Series 72)

1½"	40	-	305	35.0	38	25	73	65.0	180	123.8	28.5	4	16	11	3.0	-	F07	70	10	4	29.0
2"	50	-	368	38.2	51	38	92	95.0	215	165.1	25.4	8	30	22	15.5	-	F10	102	12	4	34.5
3"	80	-	381	44.5	76	51	127	110.0	240	190.5	25.4	8	30	22	20.0	-	F12	125	14	4	43.0

DIMENSIONS AND WEIGHTS (FULL PORT)

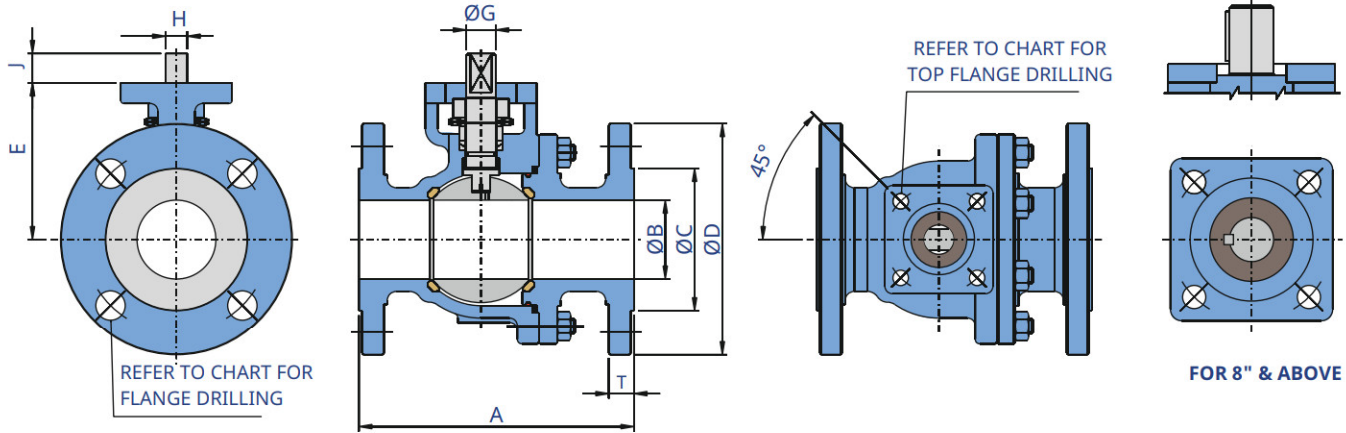

Dimensions (Inch)

ASME Class 150 (Series 65)

Valve Size		A		T	ØB	ØC	E	ØD	Flange Drilling			ØG	H	J	Key Size	Top Flange Drilling			App. Weight (lbs)	
Inch	DN	LP	SP						PCD	Hole Ø	Nos.					ISO 5211 Pattern	PCD1	Hole Ø		Nos.
½"	15	4.25	0.37	0.59	1.37	1.77	3.50	2.38	5/8	4	0.39	0.23	0.10	-	F05	1.96	0.27	4	3.10	
¾"	20	4.60	0.42	0.78	1.69	2.04	3.93	2.75	5/8	4	0.39	0.23	0.23	-	F05	1.96	0.27	4	4.40	
1"	25	5.00	0.45	0.98	2.00	2.55	4.33	3.12	5/8	4	0.63	0.43	0.25	-	F05	1.96	0.27	4	6.20	
1¼"	32	5.51	0.50	1.26	2.50	2.75	4.60	3.50	5/8	4	0.63	0.43	0.24	-	F05	1.96	0.27	4	6.83	
1½"	40	6.49	0.59	1.49	2.87	3.30	4.92	3.88	5/8	4	0.63	0.43	0.35	-	F05	1.96	0.27	4	11.50	
2"	50	7.00	0.64	2.00	3.62	3.54	5.90	4.75	¾	4	0.63	0.43	0.29	-	F07	2.76	0.39	4	17.90	
2½"	65	7.48	0.70	2.44	4.13	4.21	7.08	5.50	¾	4	0.71	0.51	0.70	-	F07	2.76	0.39	4	28.00	
3"	80	8.00	0.76	3.00	5.00	4.74	7.50	6.00	¾	4	0.75	0.51	0.63	-	F10	4.01	0.47	4	35.00	
4"	100	9.02	0.95	4.01	6.19	6.02	9.05	7.50	¾	8	0.87	0.63	0.63	-	F10	4.01	0.47	4	66.00	
5"	125	10.50	0.95	4.92	7.31	7.87	10.04	8.50	7/8	8	1.18	0.87	0.98	-	F12	4.92	0.55	4	125.00	
6"	150	15.51	10.51	1.02	5.91	8.50	8.46	11.02	9.50	7/8	8	1.18	0.87	0.98	-	F12	4.92	0.55	4	135.00
8"	200	18.00	-	1.18	7.95	10.62	11.67	13.50	11.75	7/8	8	1.57	-	1.77	0.47 x 0.31	F16	6.50	0.87	4	306.00
10"	250	20.98	-	1.22	9.92	12.75	15.94	14.25	1	12	1.65	-	2.63	0.47 x 0.31	F16	6.50	0.87	4	470.00	
12"	300	24.01	-	1.28	12.00	15.00	18.30	19.00	17.00	1	12	2.36	-	3.31	0.70 x 0.43	F25	10.00	0.71	8	795.00

ASME Class 300 (Series 66)

½"	15	5.51	0.58	0.59	1.37	1.77	3.75	2.62	5/8	4	0.39	0.23	0.10	-	F05	1.96	0.27	4	3.6	
¾"	20	5.98	0.64	0.78	1.69	2.04	4.52	3.25	¾	4	0.39	0.23	0.23	-	F05	1.96	0.27	4	5.0	
1"	25	6.50	0.70	0.98	2.00	2.56	4.92	3.50	¾	4	0.63	0.43	0.25	-	F05	1.96	0.27	4	9.3	
1¼"	32	7.00	0.75	1.26	2.50	2.75	5.23	3.88	¾	4	0.63	0.43	0.24	-	F05	1.96	0.27	4	12.1	
1½"	40	7.48	0.83	1.50	2.88	3.30	6.12	4.50	7/8	4	0.63	0.43	0.35	-	F05	1.96	0.27	4	18.0	
2"	50	8.50	0.89	2.00	3.62	3.54	6.50	5.00	¾	8	0.63	0.43	0.30	-	F07	2.76	0.39	4	25.0	
2½"	65	9.50	1.02	2.44	4.12	4.21	7.50	5.88	7/8	8	0.71	0.51	0.71	-	F07	2.76	0.39	4	43.0	
3"	80	11.12	1.14	3.00	5.00	4.74	8.25	6.62	7/8	8	0.75	0.51	0.63	-	F10	4.02	0.47	4	64.0	
4"	100	12.00	1.26	4.02	6.19	6.02	10.00	7.88	7/8	8	0.87	0.63	0.63	-	F10	4.02	0.47	4	101.0	
5"	125	15.88	1.39	4.92	7.31	7.87	11.00	9.25	7/8	8	1.18	0.87	0.98	-	F12	4.92	0.55	4	150.0	
6"	150	15.88	-	1.45	5.90	8.50	8.46	12.60	10.62	7/8	12	1.18	0.87	0.98	-	F12	4.92	0.55	4	210.0
8"	200	19.75	16.5	1.64	7.95	10.62	11.67	14.96	13.00	1	12	1.57	-	1.77	0.47 x 0.31	F16	6.50	0.87	4	352.0

ASME Class 600 (Series 67)

½"	15	6.50	0.81	0.59	1.38	2.55	3.75	2.62	5/8	4	0.63	0.43	0.11	-	F07	2.75	0.39	4	17
¾"	20	7.50	0.90	0.78	1.69	2.55	4.52	3.25	¾	4	0.63	0.43	0.11	-	F07	2.75	0.39	4	19
1"	25	8.50	0.94	0.98	1.97	2.55	4.92	3.50	¾	4	0.63	0.43	0.11	-	F07	2.75	0.39	4	22
1½"	40	9.50	1.15	1.50	2.88	3.34	6.12	4.50	7/8	4	0.87	0.63	0.49	-	F07	2.75	0.39	4	26
2"	50	11.50	1.25	2.01	3.62	4.33	6.50	5.00	¾	8	0.87	0.63	0.63	-	F10	4.01	0.47	4	41
2½"	65	13.00	1.37	2.44	4.13	5.19	7.50	5.88	7/8	8	1.18	0.87	0.87	-	F10	4.01	0.47	4	69
3"	80	14.02	1.50	3.00	5.00	5.91	8.25	6.62	7/8	8	1.18	0.87	0.86	-	F10	4.01	0.47	4	86
4"	100	17.01	1.75	4.00	6.19	6.89	10.82	8.50	1	8	1.38	0.94	1.38	-	F12	4.92	0.55	4	145

ASME Class 900 (Series 68)

1"	25	10.0	1.37	0.98	2.01	2.56	5.90	4.00	1	4	0.63	0.43	0.11	-	F07	2.75	0.39	4	40
1½"	40	12.0	1.50	1.49	2.88	3.74	7.09	4.87	1½	4	1.18	0.87	0.61	-	F10	4.01	0.47	4	63
2"	50	14.5	1.75	2.01	3.62	4.33	8.50	6.50	1	8	1.18	0.87	0.78	-	F12	4.92	0.55	4	80

DIMENSIONS AND WEIGHTS (REDUCED PORT)

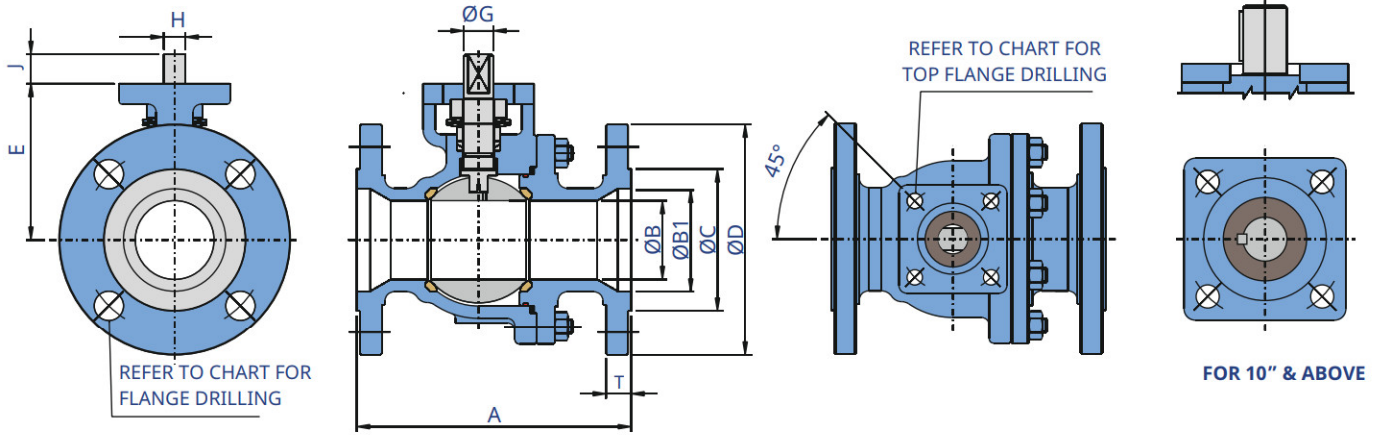

Dimensions (Inch)

ASME Class 150 (Series 69)

Valve Size		A		T	ØB1	ØB	ØC	E	ØD	Flange Drilling			ØG	H	J	Key Size	Top Flange Drilling			App. Weight (lbs)		
Inch	DN	LP	SP							PCD	Hole Ø	Nos.					PCD1	Hole Ø	Nos.			
¾"	20			4.60	0.78	0.59	1.69	1.77	3.93	2.75	5/8	4	0.39	0.23	0.10	-	F05	1.96	0.27	4	2.5	
1"	25			5.00	0.98	0.78	2.00	2.05	4.25	3.12	5/8	4	0.39	0.23	0.23	-	F05	1.96	0.27	4	4.0	
1½"	40			6.50	0.59	1.49	0.98	2.88	2.56	4.92	3.88	5/8	4	0.63	0.43	0.26	-	F05	1.96	0.27	4	10.0
2"	50			7.01	0.64	2.00	1.49	3.62	3.31	5.90	4.75	3/4	4	0.63	0.43	0.35	-	F05	1.96	0.27	4	15.0
2½"	65			7.50	0.71	2.44	2.00	4.12	3.54	7.08	5.50	3/4	4	0.63	0.43	0.30	-	F07	2.75	0.39	4	24.0
3"	80			8.00	0.76	3.00	2.44	5.00	4.21	7.48	6.00	3/4	4	0.71	0.51	0.71	-	F07	2.75	0.39	4	35.0
4"	100			9.00	0.95	4.00	3.00	6.19	4.74	9.05	7.50	3/4	8	0.75	0.51	0.63	-	F10	4.01	0.47	4	55.0
6"	150		10.50	1.02	5.91	4.02	8.50	6.02	11.00	9.50	7/8	8	0.87	0.63	0.63	-	F10	4.01	0.47	4	70.0	
8"	200	18.00		1.18	7.95	5.91	10.62	8.46	13.58	11.75	7/8	8	1.18	0.87	0.98	-	F12	4.92	0.55	4	210.0	
10"	250	20.98		1.22	9.92	7.95	12.75	11.67	15.95	14.25	1	12	1.57	-	1.77	0.47 x 0.31	F16	6.50	0.87	4	445.0	
12"	300	24.00		1.28	12.01	9.92	15.00	13.86	19.10	17.00	1	12	1.65	-	2.44	0.47 x 0.31	F16	6.50	0.87	4	685.0	

ASME Class 300 (Series 70)

¾"	20			5.98	0.64	0.78	0.59	1.69	1.77	4.52	3.25	3/4	4	0.39	0.23	0.10	-	F05	1.96	0.27	4	4
1"	25			6.50	0.70	0.98	0.78	2.00	2.05	4.92	3.50	3/4	4	0.39	0.23	0.23	-	F05	1.96	0.27	4	7
1½"	40			7.48	0.83	1.50	0.98	2.88	2.56	6.12	4.50	7/8	4	0.63	0.43	0.26	-	F05	1.96	0.27	4	12
2"	50			8.50	0.89	2.00	1.49	3.62	3.31	6.50	5.00	3/4	8	0.63	0.43	0.35	-	F05	1.96	0.27	4	20
2½"	65			9.50	1.00	2.44	2.00	4.13	3.54	7.50	5.87	7/8	8	0.63	0.43	0.30	-	F07	2.75	0.39	4	36
3"	80			11.12	1.14	3.00	2.44	5.00	4.21	8.25	6.63	7/8	8	0.71	0.51	0.71	-	F07	2.75	0.39	4	49
4"	100			12.00	1.26	4.01	3.00	6.18	4.74	10.01	7.87	7/8	8	0.75	0.51	0.63	-	F10	4.01	0.47	4	78
6"	150		15.88	1.45	5.91	4.01	8.50	6.00	12.60	10.63	7/8	12	0.87	0.63	0.63	-	F10	4.01	0.47	4	175	
8"	200		16.50	1.65	7.95	5.91	10.62	8.46	14.98	13.00	1	12	1.18	0.87	0.98	-	F12	4.92	0.55	4	320	
10"	250	22.38		1.89	9.92	7.95	12.75	11.67	17.50	15.25	1½	16	1.57	-	1.77	0.47 x 0.31	F16	6.50	0.87	4	594	

ASME Class 600 (Series 71)

¾"	20			7.48	0.90	0.78	0.59	1.69	2.55	4.52	3.25	3/4	4	0.63	0.43	0.11	-	F07	2.75	0.39	4	18
1"	25			8.50	0.96	0.98	0.78	2.00	2.55	4.92	3.50	3/4	4	0.63	0.43	0.11	-	F07	2.75	0.39	4	20
1½"	40			9.49	1.15	1.49	0.98	2.88	2.56	6.12	4.50	7/8	4	0.63	0.43	0.11	-	F07	2.75	0.39	4	26
2"	50			11.50	1.25	2.00	1.49	3.62	3.46	6.50	5.00	3/4	8	0.87	0.63	0.49	-	F07	2.75	0.39	4	33
3"	80			14.02	1.52	3.00	2.44	5.00	4.52	8.25	6.63	7/8	8	1.18	0.63	0.87	-	F10	4.01	0.47	4	88
4"	100			17.00	1.75	4.00	3.00	6.19	5.91	10.82	8.50	1	8	1.18	0.87	0.87	-	F10	4.01	0.47	4	145
6"	150			22.00	2.15	5.90	4.01	8.50	6.89	14.00	11.50	1½	12	1.38	0.94	1.38	-	F12	4.92	0.55	4	238

ASME Class 900 (Series 72)

1½"	40			12.0	1.38	1.50	0.98	2.88	2.55	7.09	4.88	1½	4	0.63	0.43	0.11	-	F07	2.75	0.39	4	65
2"	50			14.5	1.50	2.00	1.49	3.62	3.75	8.46	6.50	1	8	1.18	0.87	0.61	-	F10	4.01	0.47	4	77
3"	80			15.0	1.75	3.00	2.01	5.00	4.33	9.45	7.50	1	8	1.18	0.87	0.78	-	F12	4.92	0.55	4	95

STANDARD MATERIALS OF CONSTRUCTION

Size ½" to 3", Class 150/300

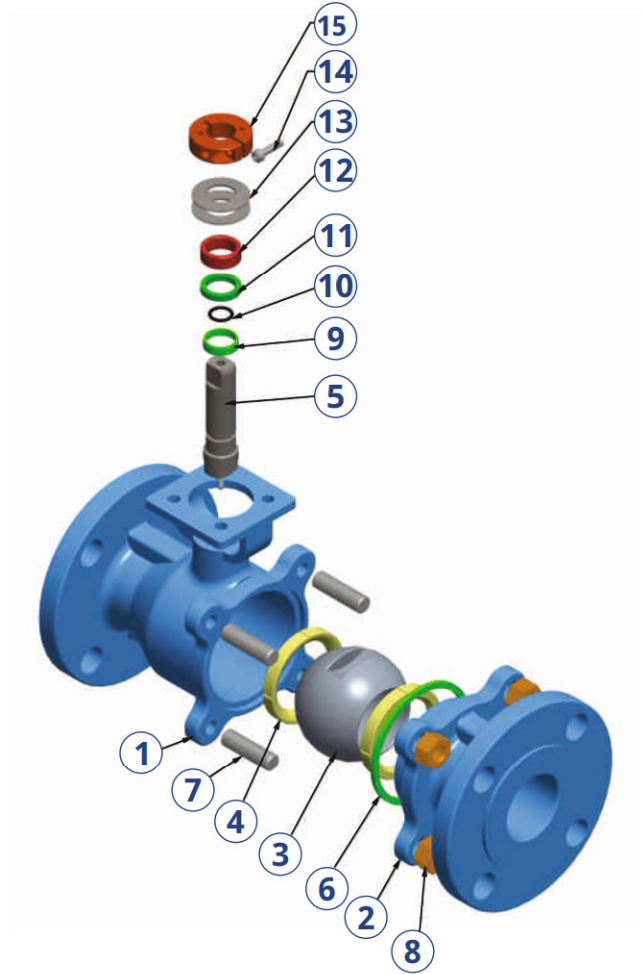

Part List

Item	Description	*Standard Material
1	Body	ASTM A216 WCB ASTM A351 CF8/CF8M/CF3/CF3M ASTM A995 4A/5A/6A
2	End Connector	ASTM A216 WCB ASTM A351 CF8/CF8M/CF3/CF3M ASTM A995 4A/5A/6A
3	Ball	ASTM A351 CF8M/CF8/CF3M ASTM A995 4A/5A/6A ASTM A182 F316/F304/F316L/F51/F53/F55
4**	Seat	PTFE/RPTFE/PEEK/ULTRA
5	Stem	ASTM A479 SS316/SS304/SS316L/ SS304L/XM-19/S31803 ASTM A182 F51/F53/F55 ASTM A564 17- 4PH Type 630
6**	Body Gasket	GRAPHITE

Item	Description	*Standard Material
7	Studs	ASTM A193 B7/B7M/B8/B8M
8	Nuts	ASTM A194 2H/2HM/8/8M
9**	Stem Seal	RPTFE/ULTRA/PEEK
10**	Stem 'O' Ring	VITON-B®/HNBR
11**	Stem Packing	GRAPHITE
12	Gland	ASTM A479 SS304
13**	Belleville Washers	EN 51 CR V4/ASTM A240 SS304
14**	Soc Hd Cap Screw	ISO 3506 A2-70
15	Gland Nut	ASTM A479 SS410/SS304

*Other materials may be available upon request.

**Recommended spares.

Note: lifting lugs/supports are not provided, unless otherwise specified by customer.

STANDARD MATERIALS OF CONSTRUCTION

4" & above, Class 150/300

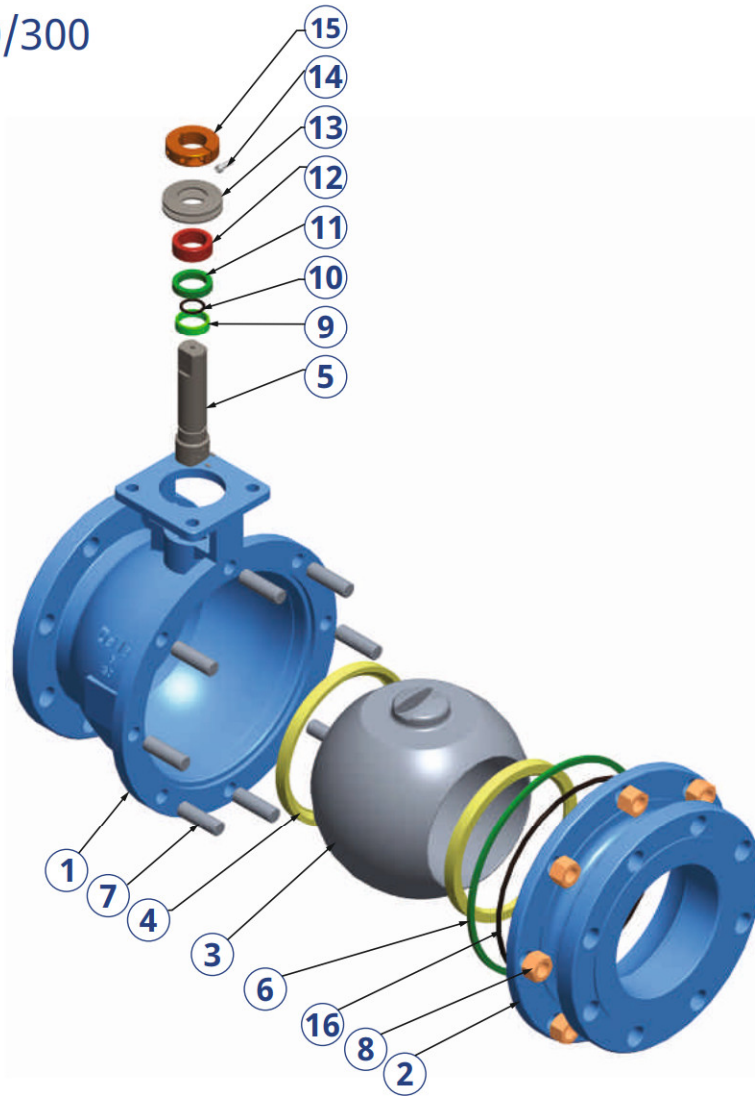

Part List

Item	Description	*Standard Material
1	Body	ASTM A216 WCB ASTM A351 CF8/CF8M/CF3/CF3M ASTM A995 4A/5A/6A
2	End Connector	ASTM A216 WCB ASTM A351 CF8/CF8M/CF3/CF3M ASTM A995 4A/5A/6A
3	Ball	ASTM A351 CF8M/CF8/CF3M ASTM A995 4A/5A/6A ASTM A182 F316/F304/F316L/F51/F53/F55
4**	Seat	PTFE/RPTFE/PEEK/ULTRA
5	Stem	ASTM A479 SS316/SS304/SS316L/SS304L/ XM-19/S31803 ASTM A182 F51/F53/F55 ASTM A564 17- 4PH Type 630
6**	Body Gasket	GRAPHITE SS316+GRAPHITE (from 6" onward)

Item	Description	*Standard Material
7	Studs	ASTM A193 B7/B7M/B8/B8M
8	Nuts	ASTM A194 2H/2HM/8/8M
9**	Stem Seal	RPTFE/ULTRA/PEEK
10**	Stem 'O' Ring	VITON-B®/HNBR
11**	Stem Packing	GRAPHITE
12	Gland	ASTM A479 SS304
13**	Belleville Washers	EN 51 CR V4/ASTM A240 SS304
14**	Soc Hd Cap Screw	ISO 3506 A2-70
15	Gland Nut	ASTM A479 SS410/SS304
16**	Body 'O' Ring (from 5" and above)	VITON-B®/HNBR

*Other materials may be available upon request.

**Recommended spares.

Note: lifting lugs/supports are not provided, unless otherwise specified by customer.

STANDARD MATERIALS OF CONSTRUCTION

Class 600/900

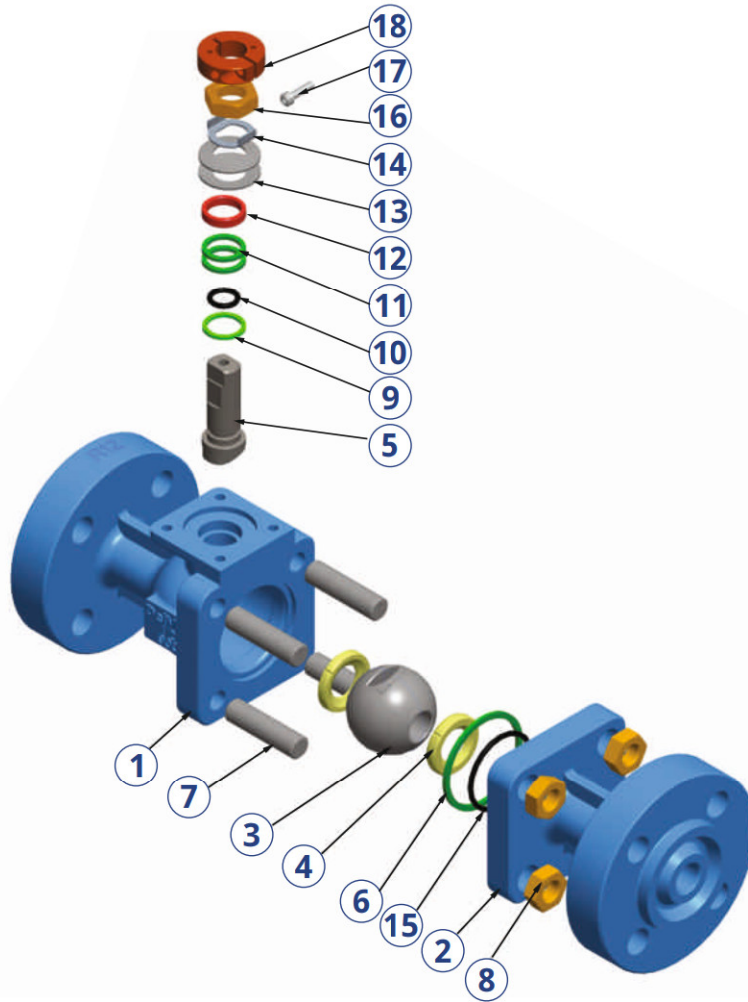

Part List

Item	Description	*Standard Material
1	Body	ASTM A216 WCB ASTM A351 CF8/CF8M/CF3/CF3M ASTM A995 4A/5A/6A
2	End Connector	ASTM A216 WCB ASTM A351 CF8/CF8M/CF3/CF3M ASTM A995 4A/5A/6A
3	Ball	ASTM A182 F316/F304/F316L/F51/F53/F55
4**	Seat	PEEK/ULTRA-X/DEVLON
5	Stem	ASTM A479 S31803/XM-19 ASTM A182 F51/F53/F55 ASTM A564 17-4 PH TYPE 630
6**	Body Gasket	GRAPHITE

Item	Description	*Standard Material
7	Studs	ASTM A193 B7/B7M/B8/B8M
8	Nuts	ASTM A194 2H/2HM/8/8M
9**	Stem Seal	PEEK/ULTRA
10**	Stem 'O' Ring	VITON-B®/HNBR
11**	Stem Packing	GRAPHITE
12	Gland	ASTM A479 SS304
13**	Belleville Washers	EN 51 CR V4/ASTM A240 SS304
14**	Locking Clip (upto 3/4")	ASTM A240 SS304
15**	Body 'O' Ring	VITON-B®/HNBR
16	Hex Lock Nut (upto 3/4")	ISO 3506 A2-70
17**	Soc Hd Cap Screw (1" and above)	ISO 3506 A2-70
18	Gland Nut (1" and above)	ASTM A479 SS410/SS304

*Other materials may be available upon request.

**Recommended spares.

Note: lifting lugs/supports are not provided, unless otherwise specified by customer.

TORQUE DATA (Nm/Lbf-Inch)

Size(FB)		TORQUE TYPE	ASME PRESSURE CLASS							
INCH	DN		150		300		600		900	
			Nm	Lbf-Inch	Nm	Lbf-Inch	Nm	Lbf-Inch	Nm	Lbf-Inch
½"	15	BTO	4	35	6	53	24	212	42	372
		ETC	3	27	5	44	19	170	34	301
¾"	20	BTO	6	53	8	71	28	248	-	-
		ETC	5	44	6	53	22	195	-	-
1"	25	BTO	10	89	15	133	65	575	85	752
		ETC	8	71	12	106	52	460	68	602
1¼"	32	BTO	15	133	21	186	-	-	-	-
		ETC	12	106	17	150	-	-	-	-
1½"	40	BTO	20	177	32	283	100	885	130	1151
		ETC	16	142	26	230	80	708	104	920
2"	50	BTO	25	221	40	354	135	1195	185	1637
		ETC	20	177	32	283	108	956	148	1310
2½"	65	BTO	40	354	60	531	220	1947	-	-
		ETC	32	283	48	425	176	1558	-	-
3"	80	BTO	65	575	100	885	305	2699	-	-
		ETC	52	460	80	708	244	2159	-	-
4"	100	BTO	110	974	170	1505	500	4425	-	-
		ETC	88	779	136	1204	400	3540	-	-
5"	125	BTO	220	1947	330	2921	-	-	-	-
		ETC	176	1558	264	2336	-	-	-	-
6"	150	BTO	330	2921	460	4071	1050	9293	-	-
		ETC	264	2336	368	3257	840	7434	-	-
8"	200	BTO	750	6638	900	7965	-	-	-	-
		ETC	600	5310	720	6372	-	-	-	-
10"	250	BTO	1175	10399	-	-	-	-	-	-
		ETC	940	8319	-	-	-	-	-	-
12"	300	BTO	1900	16815	-	-	-	-	-	-
		ETC	1520	13452	-	-	-	-	-	-

BTO: Break To Open Torque ETC: End To Close Torque

Notes:

- 1) Torque values are at ambient temperature, media being clear water without any factor of safety.
- 2) For PEEK seated valve torque multiply above valves by 2.
- 3) Above torque values are indicative and for reference only. Actuator sizing torque will depend on service media.
- 4) For reduced port valves, consider torque values corresponding to the lower size e.g., for 12"x10" reduced port valve consider torque value corresponding to 10".

DelVal® reserves rights to change the content without notice.

Operator Information



Lever Operated

Valves up to size 6" FP and 8" RP Class 150, 4" FP and 6" RP Class 300 and 2" FP and 3" RP Class 600 and 900 can be supplied with handles for manual operation. Pad locking arrangement is provided as an option to prevent unauthorized operation.



Gear Operated

Valves of all sizes can be mounted with gear operators for manual operation. Gear operators can also be attached with chain-wheel operators to open or close valves located on pipelines at high elevations.



Actuator Operated

All valves can be mounted with pneumatic or electric actuators for complete on-off automation. Valves can be also mounted with manual overrides.

100% TESTING 100% SERIALIZATION



CERTIFICATES



Manufacturing & Sales - International DelVal Flow Controls Pvt. Ltd.

Gat No: 25, Kavathe
Post-Javale, Tal. Khandala
Dist. Satara Pin-412801 | India
salesindia@delvalflow.com

Manufacturing & Sales - Americas DelVal Flow Controls USA

6068 Highway 73
Geismar, Louisiana 70734 | USA
T: +1 833-DELVAL1
F: +1 225-744-4328
sales@delvalflow.com

DelVal Arizona DelVal Flow Controls USA

1120 W Alameda Dr., Suite 3
Tempe, Arizona 85282 | USA
T: +1 623-215-7146
F: +1 623-215-7187
sales@delvalflow.com

International Projects DelVal Flow Controls USA

77 Sugar Creek Center Blvd.,
Suite 600
Sugar Land, Texas 77478 | USA
T: +1 833-DELVAL1
projects@delvalflow.com